

**Well dimensions are absolute min. plumbed dimensions**

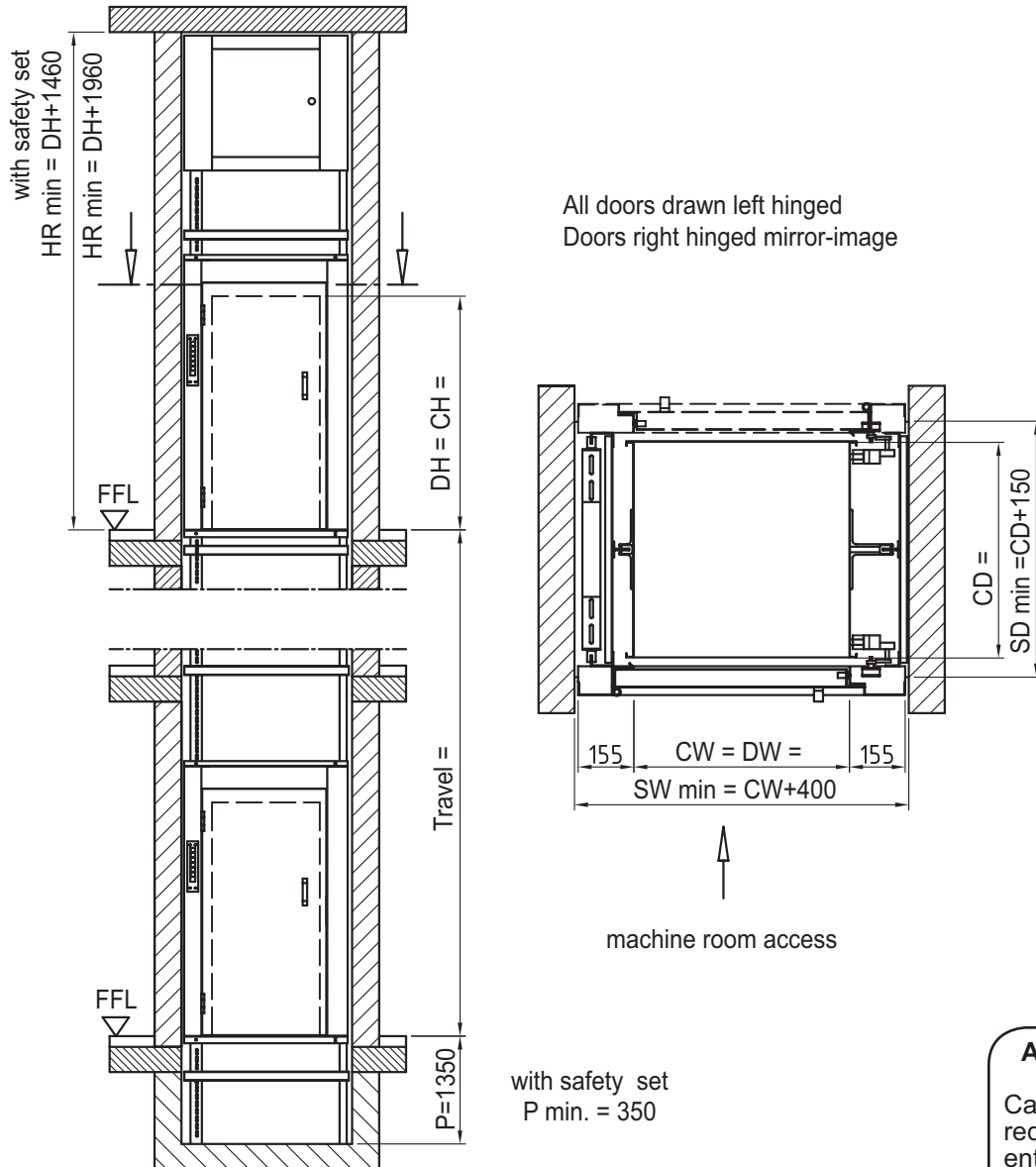

**ATTENTION:**

Cabin protection reduces clear entrance openings resp. shaft sizes (see part 10)

**Shaft floor to be constructed according to layout drawing**

Cabin width and -depth available in increments of 50 mm  
Cabin height available in increments of 100 mm

CW	=	cabin width	<b>min. 800 - max. 1400 mm</b>
CD	=	cabin depth	<b>min. 800 - max. 1400 mm</b>
CH	=	cabin height	<b>2000 with safety set - min.1200 max. 2000 mm</b>
DW	=	door width	= Cabin width
DH	=	door height	= Cabin height
P	=	pit	= <b>min. 1350 mm with safety set - min.350 mm</b>
SW	=	Shaft width	= plumbed min. dimensions
SD	=	Shaft depth	= plumbed min. dimensions
HR	=	Headroom	= clear height of top floor FFL - underside ceiling
FFL	=	finished floor level	



**Prices and specification see back side**