

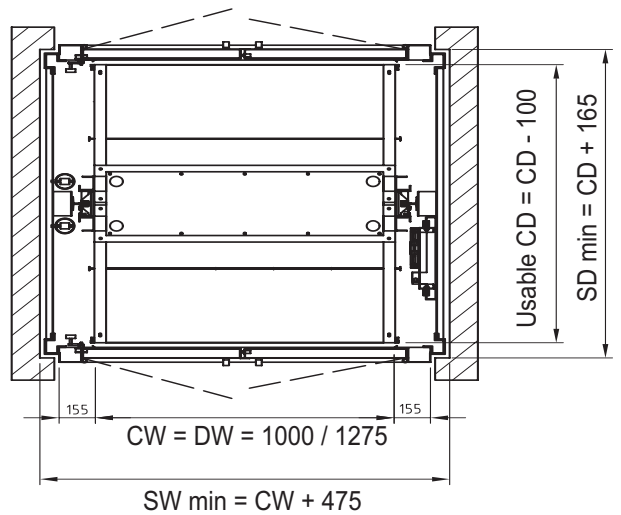

# Goodslift ISO - PM 1000

• Hinged doors serving at floor level • Loading front and rear • Machine above • WITH SAFETY GEAR

**WITH PASSENGER TRANSPORT**

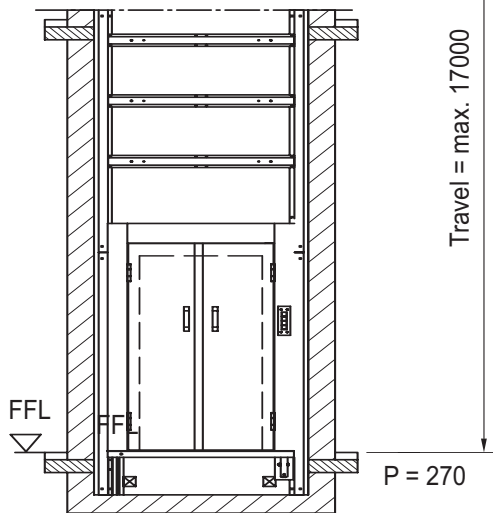
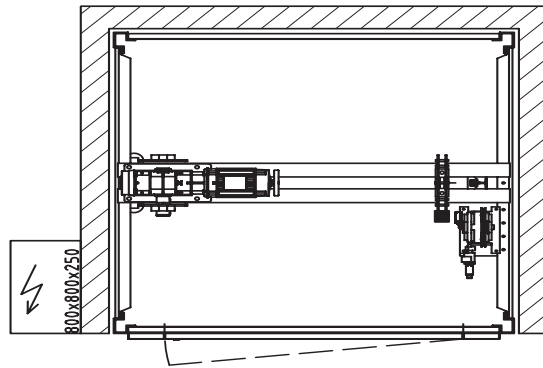
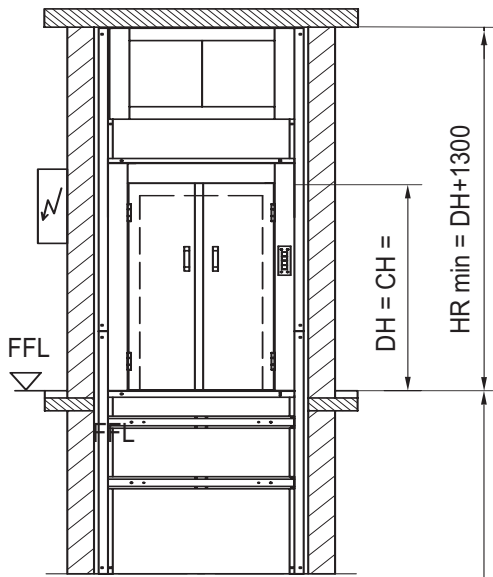

**Shaft floor to be constructed according to layout drawing**

Cabin height available in increments of 100 mm

If DW = 1000 mm then doors single hinged  
If DW = 1275 mm then doors double hinged

CW	=	cabin width	=	<b>1000</b>	<b>1275</b>	<b>1275</b>	mm
CD	=	cabin depth	=	<b>1400</b>	<b>1500</b>	<b>1800</b>	mm
CH	=	cabin height	=	<b>2000 - 2200</b>			mm
DW	=	door width	=	Cabin width			
DH	=	door height	=	Cabin height			
P	=	pit	=	min. 270 mm			
SW	=	Shaft width	=	plumbed min. dimensions			
SD	=	Shaft depth	=	plumbed min. dimensions			
HR	=	Headroom	=	clear height of top floor FFL - underside ceiling			
FFL	=	finished floor level	=				

