

**Well dimensions are absolute min. plumbed dimensions**

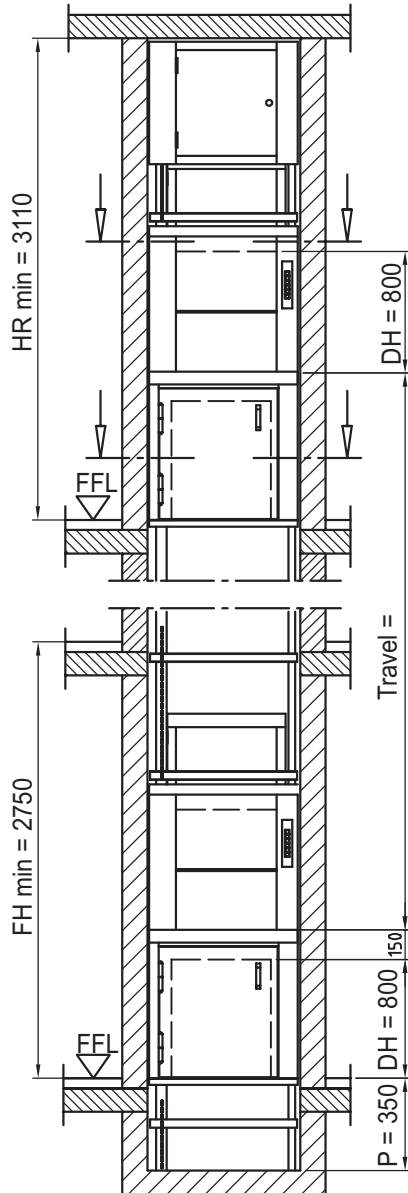

All doors drawn left hinged  
Doors right hinged mirror-image

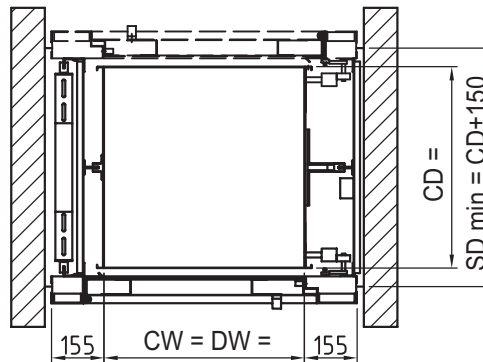
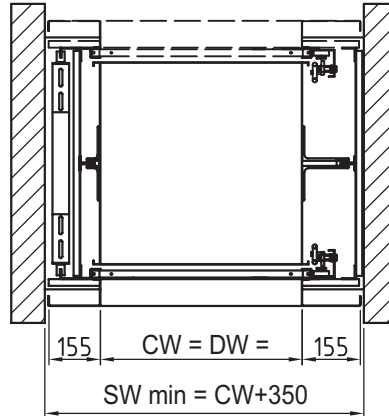

↑  
machine room access

**ATTENTION:**

Cabin protection reduces clear entrance openings resp. shaft sizes (see part 10)

**Accessible rooms underneath shaft inadmissible**

Cabin width and -depth available in increments of 50 mm  
Cabin height available in increments of 100 mm

- CW = cabin width                    **min. 500 - max. 1000 mm**
- CD = cabin depth                   **min. 600 - max. 1000 mm**
- CH = cabin height                 **1750 - 2000 mm (1750 standard dimension)**
- DH = door height                 = 800 mm each compartment
- P = pit                                 = min. 350 mm
- SW = Shaft width                   = plumbed min. dimensions
- SD = Shaft depth                   = plumbed min. dimensions
- HR = Headroom                   = clear height of top floor FFL - underside ceiling
- FFL = finished floor level
- FH = Floor to floor height on landing doors in line

**Prices and specification see back side**



• Bi-part./ hinged door • Loading front and rear • Machine above • **WITH SAFETY GEAR**

**Well dimensions are absolute min. plumbed dimensions**

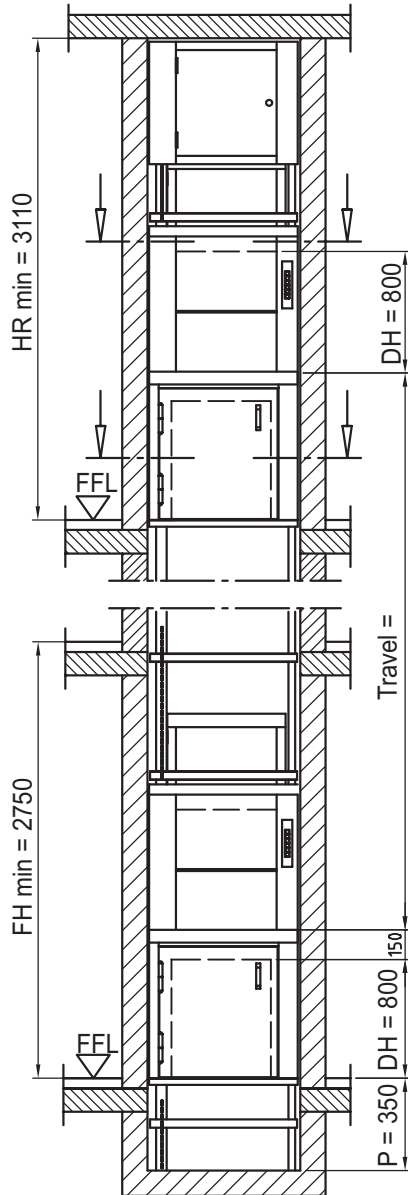

All doors drawn left hinged  
Doors right hinged mirror-image

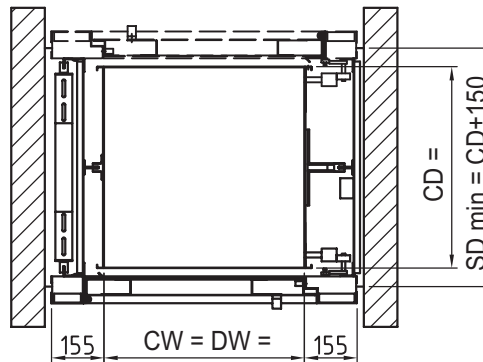
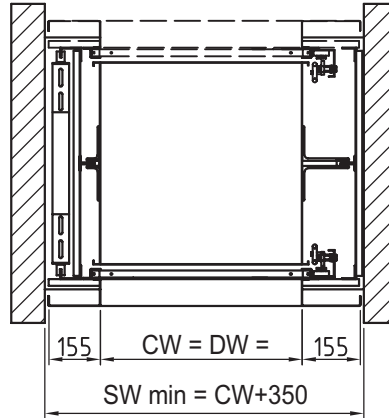

↑  
machine room access

**ATTENTION:**

Cabin protection reduces clear entrance openings resp. shaft sizes (see part 10)

**Shaft floor to be constructed according to layout drawing**

Cabin width and -depth available in increments of 50 mm  
Cabin height available in increments of 100 mm

- |     |                        |   |
|-----|------------------------|---|
| CW  | = cabin width          | <b>min. 600 - max. 1000 mm</b>                      |
| CD  | = cabin depth          | <b>min. 700 - max. 1000 mm</b>                      |
| CH  | = cabin height         | <b>1750 - 2000 mm (1750 standard dimension)</b>     |
| DW  | = door width           | = Cabin width                                       |
| DH  | = door height          | = 800 mm each compartment                           |
| P   | = pit                  | = min. 350 mm                                       |
| SW  | = Shaft width          | = plumbed min. dimensions                           |
| SD  | = Shaft depth          | = plumbed min. dimensions                           |
| HR  | = Headroom             | = clear height of top floor FFL - underside ceiling |
| FFL | = finished floor level |   |



**Prices and specification see back side**